



## Fault Tolerant Parallel Filters based on Error Correction Codes

Ms G.Sravani Miss. C. NIRMALA

**Abstract:** In signal processing and communication systems digital filters are widely used. The reliability of those systems is critical in some cases, and fault tolerant filter implementations are needed. Many techniques that exploit the filters' structure and properties to achieve fault tolerance have been proposed over the years. As technology scales, it enables more complex systems that incorporate many filters. In those complex systems, it is common that some of the filters operate in parallel, for example, by applying the same filter to different input signals. Recently, a simple technique that exploits the presence of parallel filters to achieve fault tolerance has been presented. In this brief, that idea is generalized to show that parallel filters can be protected using error correction codes (ECCs) in which each filter is the equivalent of a bit in a traditional ECC. This new scheme allows more efficient protection when the number of parallel filters is large. The technique is evaluated using a case study of parallel finite impulse response

filters showing the effectiveness in terms of protection and implementation cost.

### 1. INTRODUCTION

Electronic circuits are increasingly present in automotive, medical, and space applications where reliability is critical. In those applications, the circuits have to provide some degree of fault tolerance. This need is further increased by the intrinsic reliability challenges of advanced CMOS technologies that include, e.g., manufacturing variations and soft errors. A number of techniques can be used to protect a circuit from errors. Those range from modifications in the manufacturing process of the circuits to reduce the number of errors to adding redundancy at the logic or system level to ensure that errors do not affect the system functionality. To add redundancy, a general technique known as triple modular redundancy (TMR) can be used. The TMR, which triplicates the design and adds voting logic to correct errors, is commonly used. However, it more than triples the area and



power of the circuit, something that may not be acceptable in some applications. When the circuit to be protected has algorithmic or structural properties, a better option can be to exploit those properties to implement fault tolerance. One example is signal processing circuits for which specific techniques have been proposed over the years. Digital filters are one of the most commonly used signal processing circuits and several techniques have been proposed to protect them from errors. Most of them have focused on finite-impulse response (FIR) filters. The use of reduced precision replicas was proposed to reduce the cost of implementing modular redundancy in FIR filters. A relationship between the memory elements of an FIR filter and the input sequence was used to detect errors. Other schemes have exploited the FIR properties at a word level to also achieve fault tolerance. The use of residue number systems [6] and arithmetic codes has also been proposed to protect filters. Finally, the use of different implementation structures of the FIR filters to correct errors with only one redundant module has also been proposed. In all the techniques mentioned so far, the protection

of a single filter is considered. However, it is increasingly common to find systems in which several filters operate in parallel. This is the case in filter banks and in many modern communication systems. For those systems, the protection of the filters can be addressed at a higher level by considering the parallel filters as the block to be protected. This idea was explored where two parallel filters with the same response that processed different input signals were considered. It was shown that with only one redundant copy, single error correction can be implemented. Therefore, a significant cost reduction compared with TMR was obtained. In this brief, a general scheme to protect parallel filters is presented. Parallel filters with the same response that process different input signals are considered. The new approach is based on the application of error correction codes (ECCs) using each of the filter outputs as the equivalent of a bit in an ECC codeword. This is a generalization of the scheme presented and enables more efficient implementations when the number of parallel filters is large. The scheme can also be used to provide more powerful protection using advanced ECCs that can

correct failures in multiples modules. The rest of this brief introduces the new scheme by first summarizing the parallel filters considered the proposed scheme is presented. presents a case study to illustrate the effectiveness of the approach.

## 2 2. PARALLEL FILTERS WITH THE SAME RESPONSE

A discrete time filter implements the following equation:  $y[n] = \sum_{l=-\infty}^{\infty} x[l]h[n-l]$  where  $x[n]$  is the input signal,  $y[n]$  is the output, and  $h[l]$  is the impulse response of the filter. When the response  $h[l]$  is nonzero, only for a finite number of samples, the filter is known as a FIR filter, otherwise the filter is an infinite impulse response (IIR) filter. There are several structures to implement both FIR and IIR filters. International Journal of Computer Applications (0975 – 8887) National Conference on Advances in Computing, Communication and Networking (ACNet – 2016) 12 In the following, a set of  $k$  parallel filters with the same response and different input signals are considered. These parallel filters are

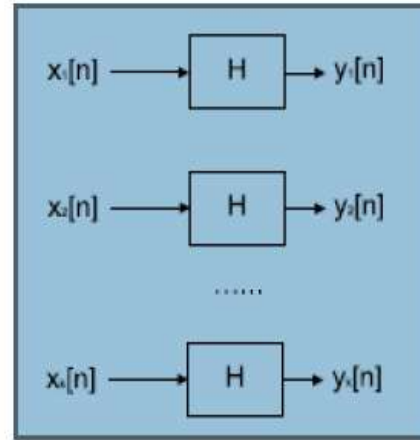

Fig. 1. Parallel filters with the same response

Illustrated in Fig. 1. This kind of filter is found in some communication systems that use several channels in parallel. In data acquisition and processing applications is also common to filter several signals with the same response. An interesting property for these parallel filters is that the sum of any combination of the outputs  $y_i[n]$  can also be obtained by adding the corresponding inputs  $x_i[n]$  and filtering the resulting signal with the same filter  $h[l]$ .  $\sum_{i=1}^k x_i[n] = x[n]$  This simple observation will be used in the following to develop the proposed fault tolerant implementation.

## 3 PROPOSED SCHEME

The new technique is based on the use of the ECCs. A simple ECC takes a block of  $k$  bits and produces a block of  $n$  bits by adding  $n-k$  parity check bits. The parity check bits



are XOR combinations of the k data bits. By properly designing those combinations it is possible to detect and correct errors. As an example, let us consider a simple Hamming code with  $k = 4$  and  $n = 7$ . In this case, the three parity check bits,  $p_1, p_2, p_3$ , are computed as a function of the data bits. The data and parity check bits are stored and can be recovered later even if there is an error in one of the bits. This is done by recomputing the parity check bits and comparing the results with the values stored. In the example considered, an error on  $d_1$  will cause errors on the three parity checks; an error on  $d_2$  only in  $p_1$  and  $p_2$ ; an error on  $d_3$  in  $p_1$  and  $p_3$ ; and finally an error on  $d_4$  in  $p_2$  and  $p_3$ . Therefore, the data bit in error can be located and the error can be corrected. This is commonly formulated in terms of the generating G and parity check H matrixes. For the Hamming code considered in the example, those are

Table 1. Error Location in the Hamming Code

$s_1 s_2 s_3$	Error Bit Correction	Action
0 0 0	No error	None
1 1 1	$d_1$	correct $d_1$
1 1 0	$d_2$	correct $d_2$
1 0 1	$d_3$	correct $d_3$
0 1 1	$d_4$	correct $d_4$
1 0 0	$p_1$	correct $p_1$
0 1 0	$p_2$	correct $p_2$
0 0 1	$p_3$	correct $p_3$

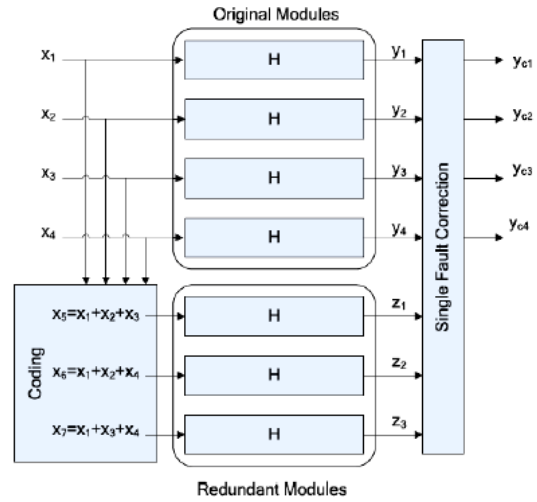

Fig. 2. Proposed scheme for four filters and a Hamming code

the checking is done by testing if  $[y] = [y] - [y] - [y]$ . For example, an error on filter  $y_1$  will cause errors on the checks of  $z_1, z_2,$  and  $z_3$ . Similarly, errors on the other filters will cause errors on a different group of  $z_i$ . Therefore, as with the traditional ECCs, the error can be located and corrected. The overall scheme is illustrated on Fig. 2. It can be observed that correction is achieved with only three redundant filters. For the filters, correction is achieved by reconstructing the erroneous outputs using the rest of the data and check outputs. For example, when an error on  $y_1$  is detected, it can be corrected by making  $[y] = [y] - [y] - [y]$ . Similar equations can be used to correct errors on the rest of the data outputs. In our case, we can define the check matrix as  $H$  and calculate



$s = yHT$  to detect errors. Then, the vector  $s$  is also used to identify the filter in error. In our case, a nonzero value in vector  $s$  is equivalent to 1 in the traditional Hamming code. A zero value in the check corresponds to a 0 in the traditional Hamming code. It is important to note that due to different finite precision effects in the original and check filter implementations, the comparisons can show small differences. Those differences will depend on the quantization effects in the filter implementations that have been widely studied for different filter structures. The interested reader is referred to for further details. Therefore, a threshold must be used in the comparisons so that values smaller than the threshold are classified as 0. This means that small errors may not be corrected. This will not be an issue in most cases as small errors are acceptable. The detailed study of the effect of these small errors on the signal to noise ratio at the output of the filter is left for future work. The reader can get more details on this type of analysis . With this alternative formulation, it is clear that the scheme can be used for any number of parallel filters and any linear block code can be used. The

approach is more attractive when the number of filters  $k$  is large. For example, when  $k = 11$ , only four redundant filters are needed to provide single error correction. This is the same as for traditional ECCs for which the overhead decreases as the block size increases. The additional operations required for encoding and decoding are simple additions, subtractions, and comparisons and should have little effect on the overall complexity of the circuit. This is illustrated in Section IV in which a case study is presented. In the discussion, so far the effect of errors affecting the encoding and decoding logic has not been considered. The encoder and decoder include several additions and subtractions and therefore the possibility of errors affecting them cannot be neglected. Focusing on the encoders, it can be seen that some of the calculations of the  $z_i$  share adders. For example, looking at (6),  $z_1$  and  $z_2$  share the term  $y_1 + y_2$ . Therefore, an error in that adder could affect both  $z_1$  and  $z_2$  causing a miscorrection on  $y_2$ . To ensure that single errors in the encoding logic will not affect the data outputs, one option is to avoid logic sharing by computing each of the  $z_i$  independently. In



that case, errors will only affect one of the  $z_i$  outputs and according to Table I, the data outputs  $y_j$  will not be affected. Similarly, by avoiding logic sharing, single errors in the computation of the  $s$  vector will only affect one of its bits. The final correction elements such as that need to be tripled to ensure that they do not propagate errors to the outputs.

Table 2. Resource comparison for four parallel FIR filters

	Unprotected	TMR	Method in [7]	Proposed
Slices	2944	9020	7740	6409
Flip-flops	1224	3984	3980	2941
LUTs	5692	17256	13640	12032

Table 3. Resource comparison for eleven parallel FIR filters

	Unprotected	TMR	Method in [7]	Proposed
Slices	8096	24805	21285	14422
Flip-flops	3366	10956	10946	6478
LUTs	15653	47454	37510	28331

#### 4. CONCLUSIONS

This brief has presented a new scheme to protect parallel filters that are commonly found in modern signal processing circuits. The approach is based on applying ECCs to the parallel filters outputs to detect and correct errors. The scheme can be used for parallel filters that have the same response and process different input signals. TMR method can also detect multi-bit errors in any filters but consumes more area and power whereas ECC scheme can detect and

correct only single bit error. A case study has also been discussed to show the effectiveness of the scheme in terms of error correction and also of circuit overheads. The technique provides larger benefits when the number of parallel filters is large. The proposed scheme can also be applied to the IIR filters. Future work will consider the evaluation of the benefits of the proposed technique for IIR filters. The extension of the scheme to parallel filters that have the same input and different impulse responses is also a topic for future work. Future work also includes the research of FPGA oriented solutions for fault tolerant digital filters and the consideration of power consumption as a metric for optimization, since it is a key factor in space applications. The proposed scheme can also be combined with the reduced precision replica approach presented to reduce the overhead required for protection. This will be of interest when the number of parallel filters is small as the cost of the proposed scheme is larger in that case. Another interesting topic to continue this brief is to explore the use of more powerful multibit ECCs, such as Bose–



Chaudhuri–Hocquenghem codes, to correct errors on multiple filters.

## REFERENCES

- [1] M. Nicolaidis, “Design for soft error mitigation,” *IEEE Trans. Device Mater. Rel.*, vol. 5, no. 3, pp. 405–418, Sep. 2005.
- [2] A. Reddy and P. Banarjee “Algorithm-based fault detection for signal processing applications,” *IEEE Trans. Comput.*, vol. 39, no. 10, pp. 1304–1308, Oct. 1990.
- [3] B. Shim and N. Shanbhag, “Energy-efficient soft error-tolerant digital signal processing,” *IEEE Trans. Very Large Scale Integr. (VLSI) Syst.*, vol. 14, no. 4, pp. 336–348, Apr. 2006.
- [4] T. Hitana and A. K. Deb, “Bridging concurrent and non-concurrent error detection in FIR filters,” in *Proc. Norchip Conf.*, 2004, pp. 75–78.
- [5] Y.-H. Huang, “High-efficiency soft-error-tolerant digital signal processing using fine-grain subword-detection processing,” *IEEE Trans. Very Large Scale Integr. (VLSI) Syst.*, vol. 18, no. 2, pp. 291–304, Feb. 2010.
- [6] S. Pontarelli, G. C. Cardarilli, M. Re, and A. Salsano, “Totally fault tolerant RNS based FIR filters,” in *Proc. IEEE IOLTS*, Jul. 2008, pp. 192–194.
- [7] Z. Gao, W. Yang, X. Chen, M. Zhao, and J. Wang, “Fault missing rate analysis of the arithmetic residue codes based fault-tolerant FIR filter design,” in *Proc. IEEE IOLTS*, Jun. 2012, pp. 130–133.
- [8] P. Reviriego, C. J. Bleakley, and J. A. Maestro, “Structural DMR: A technique for implementation of soft-error-tolerant FIR filters,”
- [9] P. P. Vaidyanathan. *Multirate Systems and Filter Banks*. Upper Saddle River, NJ, USA: Prentice-Hall, 1993
- [10] A. Sibille, C. Oestges, and A. Zanella, *MIMO: From Theory to Implementation*. San Francisco, CA, USA: Academic Press, 2010.
- [11] P. Reviriego, S. Pontarelli, C. Bleakley, and J. A. Maestro, “Area efficient concurrent error detection and correction for parallel filters,” *IET Electron. Lett.*, vol. 48, no. 20, pp. 1258–1260, Sep. 2012.
- [12] A. V. Oppenheim and R. W. Schaffer, *Discrete Time Signal Processing*. Upper Saddle River, NJ, USA: Prentice-Hall 1999



[13] S. Lin and D. J. Costello, *Error Control Coding*, 2nd ed. Englewood Cliffs, NJ, USA: Prentice-Hall. 2004.

[14] R. W. Hamming, “Error correcting and error detecting codes,” *Bell Syst. Tech. J.*, vol. 29, pp. 147–160, Apr. 1950.

Rajampet, Kadapa, AP. She received her M.Tech from Annamacharya Institute of Technology and Science, New Boyanapalli, Rajampet, AP.

## Author’s Biography



G. SRAVANI received her B.Tech degree from Modugula Kalavathamma Institute of Technology for Women (affiliated by JNTU Anantapuram) Department of ECE. She is pursuing M.Tech in Modugula Kalavathamma Institute of Technology for Women, Rajampet, Kadapa, AP.



Miss. C. NIRMALA is currently working as an associate professor in ECE Department, Modugula Kalavathamma Institute of Technology for Women,